

FLANGED DETAIL

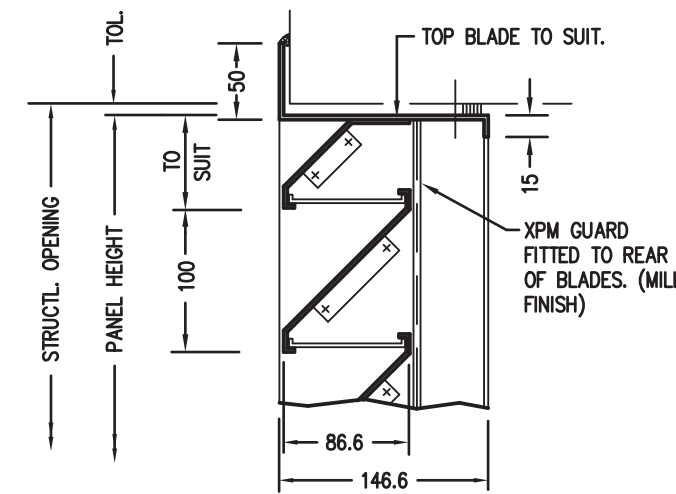

700. HEAD DETAIL

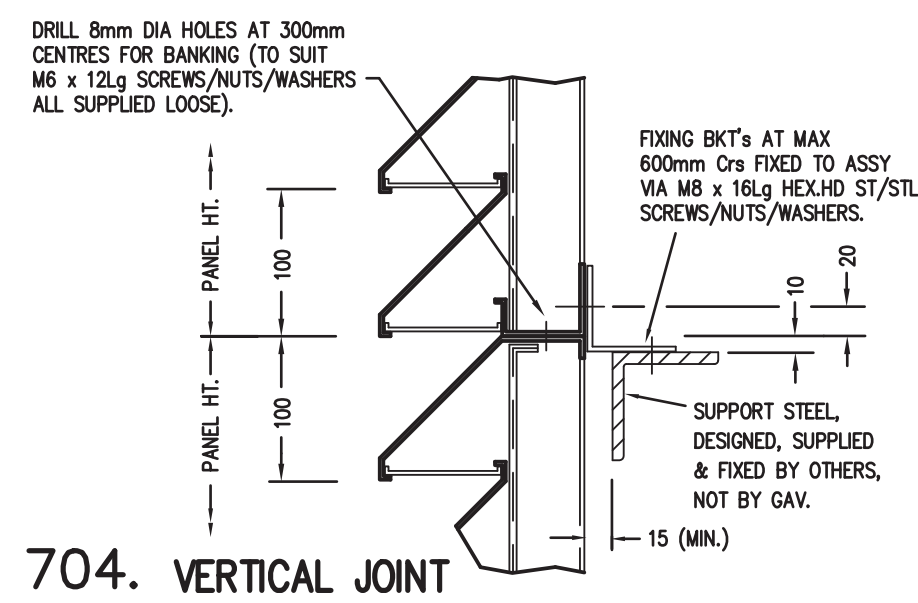

704. VERTICAL JOINT

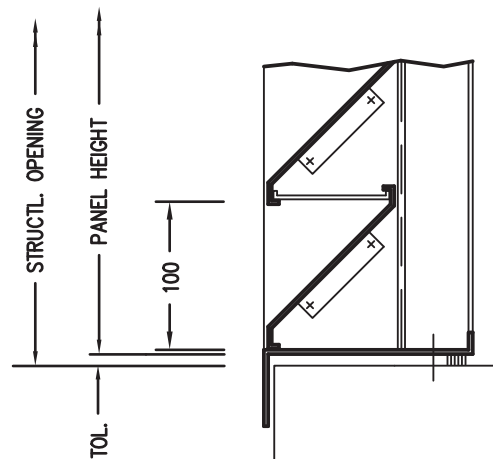

701. 100 BLADE CILL DETAIL

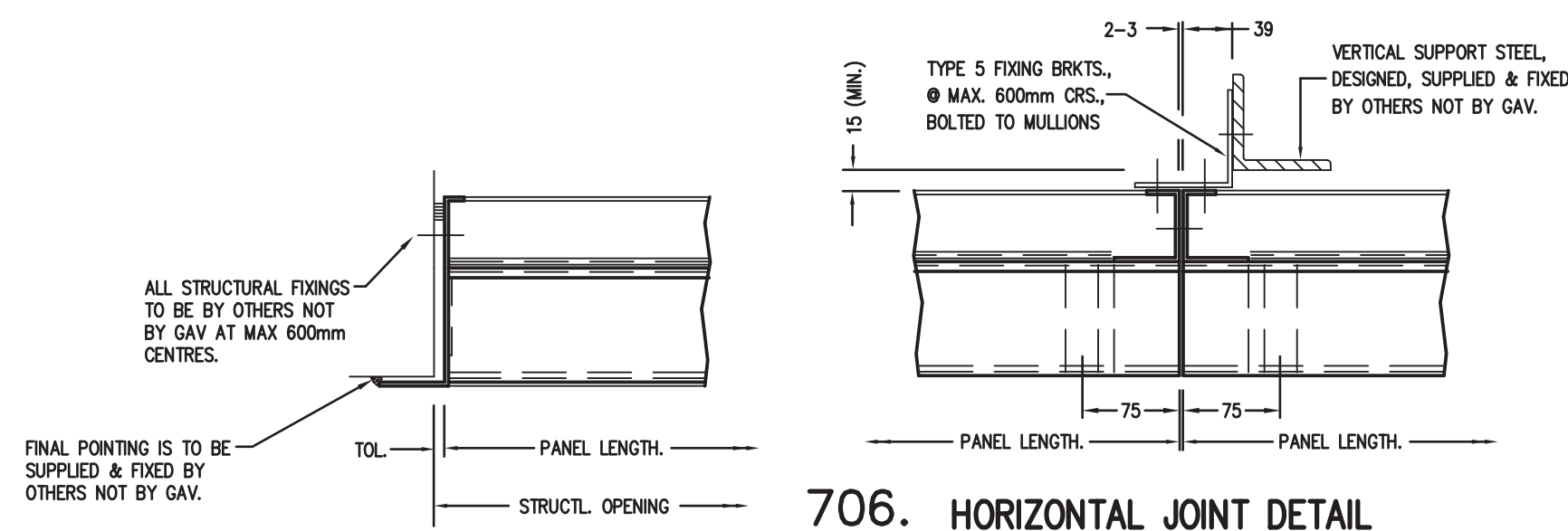

706. HORIZONTAL JOINT DETAIL

702. JAMB DETAIL

FRAMED DETAIL

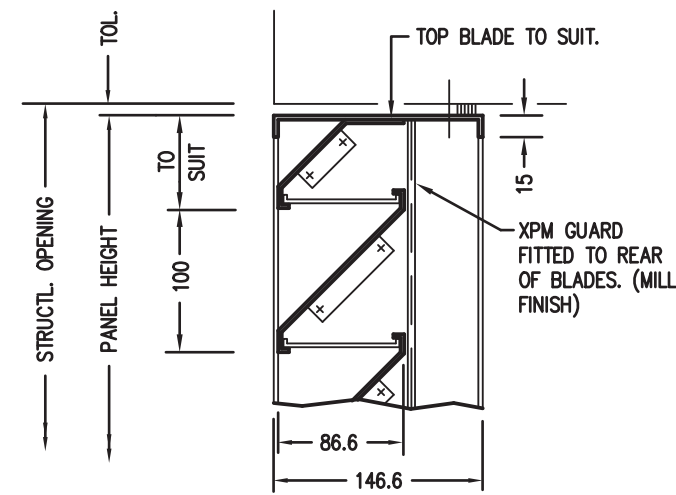

707. HEAD DETAIL

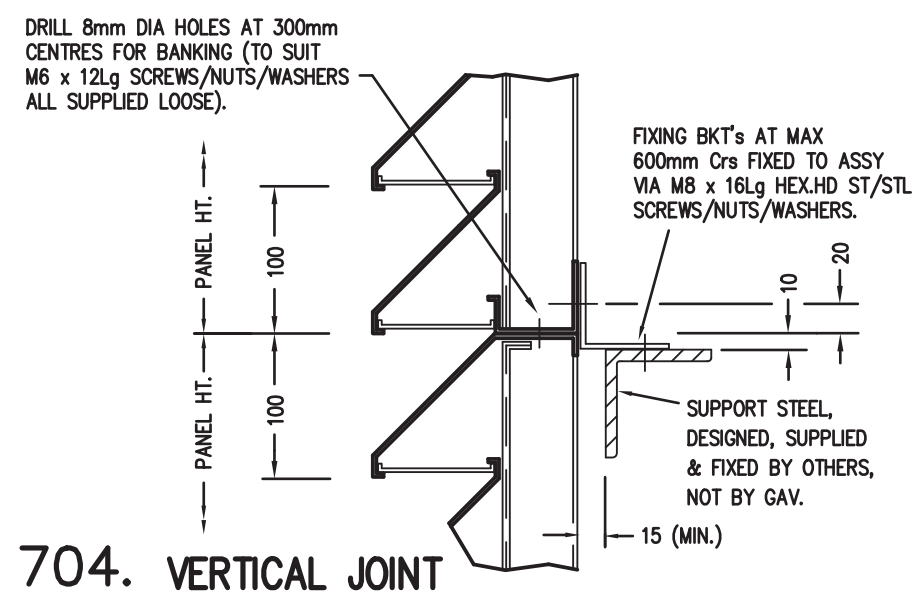

704. VERTICAL JOINT

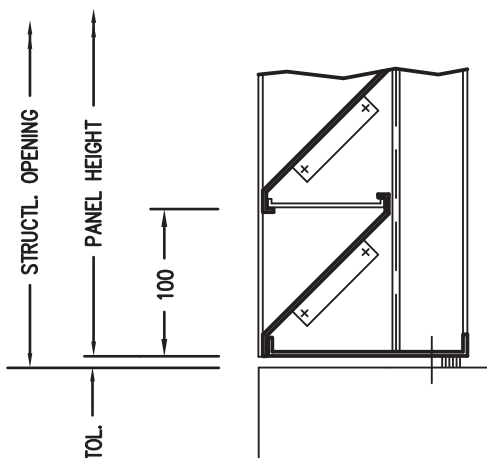

708. 100 BLADE CILL DETAIL

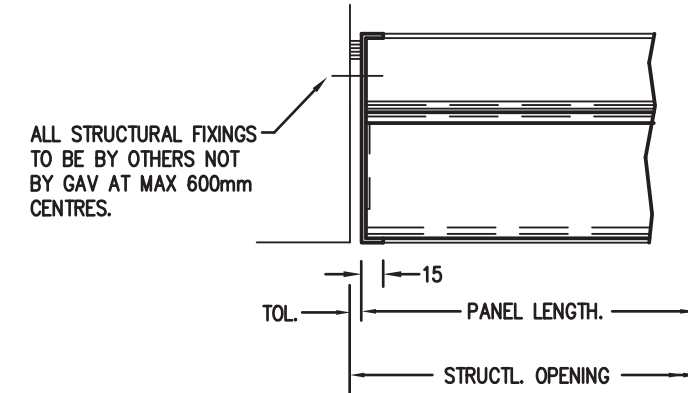

709. JAMB DETAIL

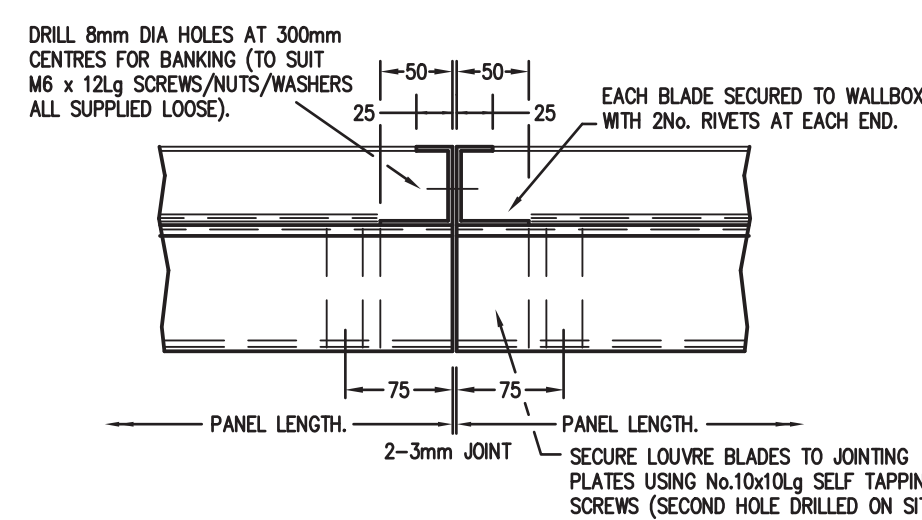

703. HORIZONTAL JOINT DETAIL

DOOR DETAIL

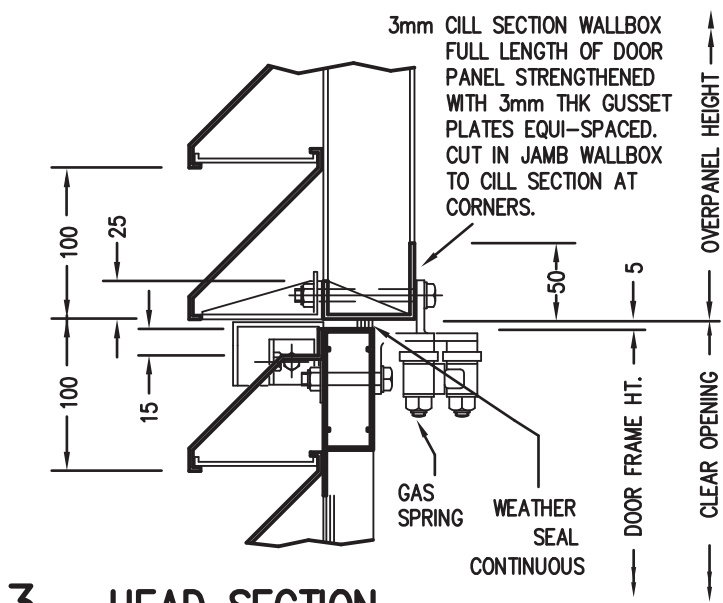

723. HEAD SECTION

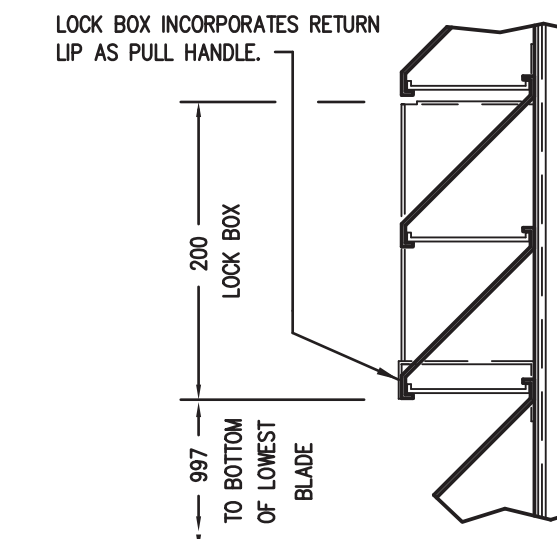

722. LOCKBOX

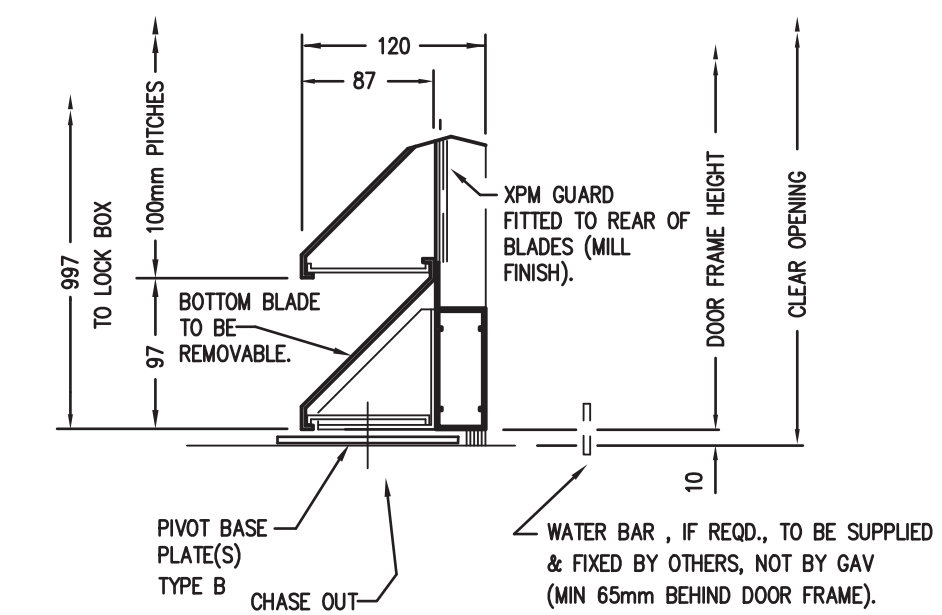

721. DOOR CILL

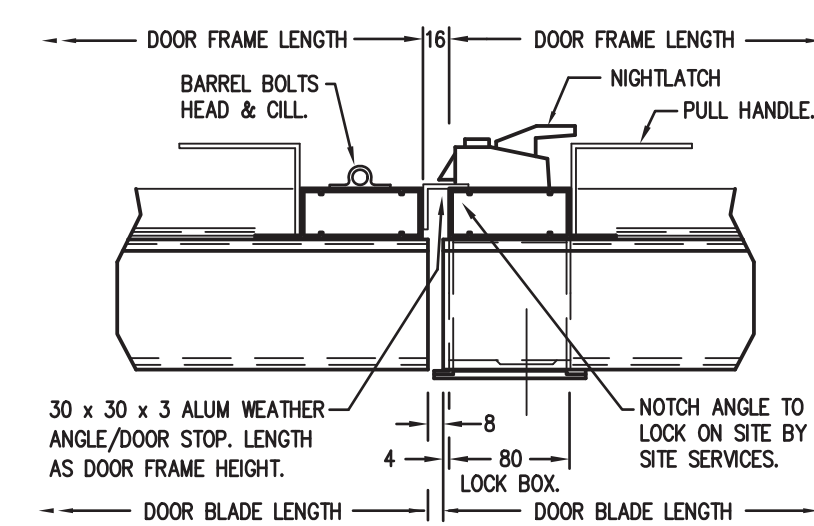

724. MEETING LOCK STILES

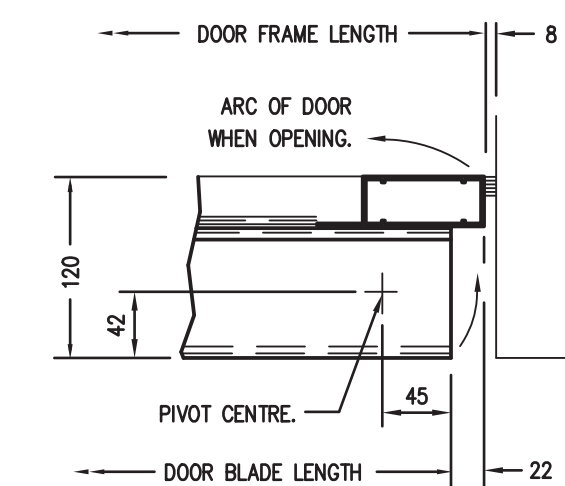

725. R/H D FRAME INTO STRUCTURE

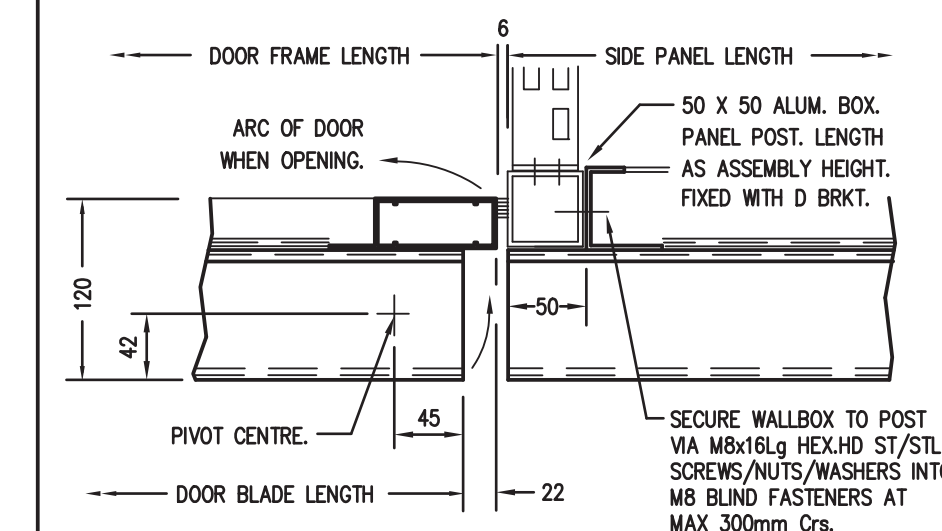

727. R/H D FRAME INTO ASSEMBLY

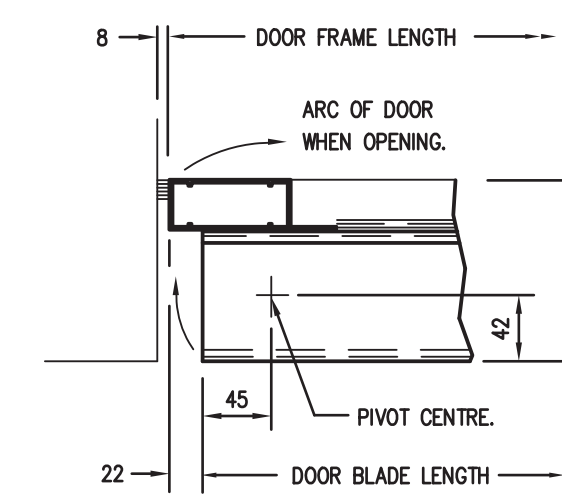

726. L/H D FRAME INTO STRUCTURE

SO SUPPLY ONLY S&F SUPPLY & FIX

LOUVRE TYPE : LOUVRE_TYPE
 TRIM TYPE : TRIM_TYPE
 GUARD TYPE : GUARD_TYPE
 PAINT TYPE : PAINT_TYPE
 FINISH : FINISH
 COLOUR : COLOUR
 LOCATION : LOCATION
 CUSTOMERS REF : CUST_REF'S
 GAV REF : GAV_REF'S
 DO NOT SCALE DRAWING, IF IN DOUBT ASK.
 ALL DETAILS & DIMENSIONS MUST BE CONFIRMED AS CORRECT BEFORE MANUFACTURE OF LOUVRES CAN COMMENCE.
 CUSTOMER DRAWINGS USED :-
 CUST_DRAWINGS_USED

Rev	Description	Mod. By	Date

© COPYRIGHT 2009 HUNTER PRODUCTS
 THIS DRAWING & DESIGN ARE THE PROPERTY OF HUNTER PRODUCTS GROUP., AND MUST NOT BE COPIED OR USED IN ANY WAY PREJUDICIAL TO THEIR INTERESTS.

Project

Customer

Drawing Title

Location/Panel Ref.

100mm FABRICATED LOUVRE

Drawing No. DWG_NO Sheet No. SHT Revision REV

Scale SCALE Date DATE

Computer File No. COMPUTER_FILE_NO Project No. CONTRACT_NO

Drawn By DRAWN_BY Checked By CHKD_BY

Coordinated By CONTRACT_ENGINEER Approved By APP'VD_BY



NOTE: The details shown within this drawing are for use as an aid only. If you are unsure which blocks are best suited for your application please contact our technical team on (0161) 763 3735 and we will be

© COPYRIGHT 2009 HUNTER PRODUCTS
 THIS DRAWING & DESIGN ARE THE PROPERTY OF HUNTER PRODUCTS GROUP., AND MUST NOT BE COPIED OR USED IN ANY WAY PREJUDICIAL TO THEIR INTERESTS.